

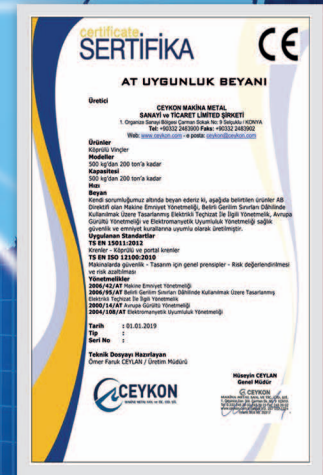

CEYKON®

MAKİNE - VİNÇ GRUPLARI
MACHINE - CRANE GROUPS

www.ceykon.com.tr

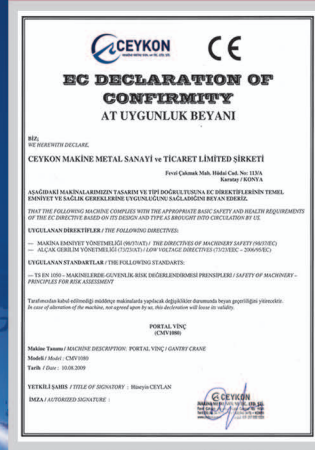
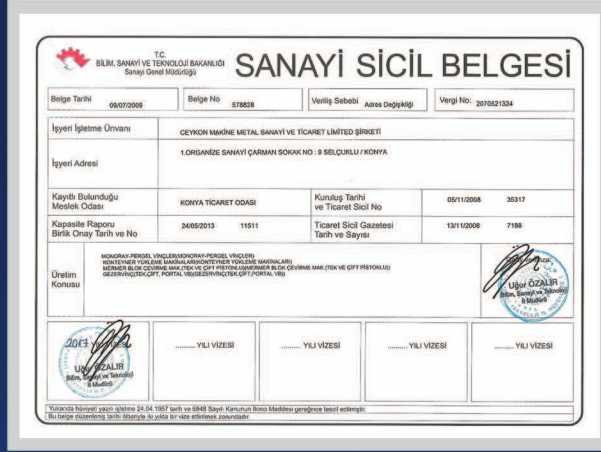

Uzun yıllar önce farklı ürün grupları ile hayata geçen şirketimiz, siz değerli müşterilerimize en yüksek kalite ve en iyi fiyat ilkesi ile sunduğumuz vinçlerin imalatına başladı. Üretime başladığımız ilk günden beri kalite standartlarımızı devamlı artırarak üretimimize hızla devam etmekteyiz.

İşletmemiz bünyesinde monoray, çift kirişli gezer köprü, portal ve pergel vinç imalatı büyük bir özen ve yüksek teknolojinin sağladığı tüm imkanlar ile profesyonel teknik ekibimiz ve uzman mühendislik kadromuz tarafından gerçekleştirilmektedir. Üretim kapasitemiz ise her yıl yükselen bir trend göstermektedir. Hedeflerimiz arasında kapasitemizi her yıl bir önceki yıla göre %20 daha artırmak yer almaktadır. Şirketimiz gelişen ülkemiz sanayisine ve sanayicilerine kusursuz hizmet vermenin yanı sıra ülke sınırları dışında da dünyanın önde gelen pazarlarında uluslar arası rakipleri ile rekabet eder hale gelmiştir. Makine ve mermer sektörlerine yoğun olarak hizmet vermekte olup Kuzey Afrika ve Körfez bölgeleri başta olmak üzere Cezayir, Fas, Tunus, Libya, Kuveyt, Katar, Dubai, S. Arabistan, Irak, Lübnan, Azerbaycan, Romanya, Makedonya, Rusya, Almanya, Hırvatistan, Mısır, Senegal gibi sektörlerde iddialı olan ülkelere yoğun olarak ihracat yapmaktayız.

Şirketimiz bünyesinde en alt kademeden en üst yönetim kadrosuna kadar sürekli gelişme ve sürekli müşteri memnuniyeti felsefesini benimsemiş bulunmaktayız. Geride bıraktığımız yıllar içerisinde gerek sahip olduğumuz mevcut kapasiteyi artırarak ve gerekse 21. yüzyılın getirdiği teknolojik ve bilimsel yenilikleri benimseyerek 2019 yılına bir önceki yıldan bir adım daha ileride başlamanın sevincini yaşamaktayız. Bu gelişmemizin arka planındaki en önemli etken olan siz değerli müşterilerimize teşekkürü bir borç biliyoruz. 21. yüzyılın getirdiği teknolojik, bilimsel, yönetsel ve kültürel gelişmeleri yakından takip ederek ve sizlere daha faydalı olabileceğini düşündüğümüz her yeniliği bünyemize entegre ederek her yeni gün sahip olduğumuz değerlere değer katmaktayız. Gücümüzün kaynağı olan siz müşterilerimizi memnun etmeyi her şeyin önünde tutan firmamız sadece satış esnasında değil satış sonrasında da 7 gün 24 saat, sorunlarınıza en hızlı ve ekonomik çözüm üretmek gayesiyle gezici servis kadromuzu büyütmüş ve yurtiçindeki her noktaya en geç 1 gün içinde intikal eder duruma getirmiştir.

Our company was founded in many years ago under different product groups and started manufacturing of cranes with principle of the most acceptable prices and highest quality to you, our highly respectable customers. In our company, we produce monorail, double girder, gantry and jib cranes elaborately and with all facilities that is provided by technology and by our expert technical and engineering team. Our production capacity tends toward progress trend in each year. Increasing our capacity by the rate of 20% as against each passing year. Our company has been competitive even exterritory of Turkey between competitors in worlds top popular markets besides serving excelently to our developing industry and industrialists. Our machines are currently exported to high-toned countries like Algeria, Morocco, Tunisia, Libya, Kuwait, Qatar, Dubai, S. Arabia, Iraq, Lebanon, Azerbaijan, Romania, Macedonia, Russia, Germany, Croatia, Egypt, Senegal. We seized on philosophy of consistent customer satisfaction and improvement from sub to top grade We are happy to begin 2019 one jump ahead than lastyear as both increasing our capacity and seizing on technological and scientific developments that was gained by 21 st century. We want to thankyou our worthy customers who are the most important cause in background of our development We are adding value to our existing values as intergating ali innovations which can be useful for you and following technological, scientific, administrative and culturel developments. Our company which keeps forefront our customers satisfaction who are the source of our success, not only during sale but also in after-sales service developed its service çuality in order to solve your problems fastly and economically during 7days 24 hours. So we can reach each point latest in 1 day around in Türkiye.

ARABALI KALDIRMA GRUBU

TROLLEY TYPE HOISTING GROUP

Arabalı kaldırma grubundaki makinelerimiz 1 ton'dan 200 ton kapasiteye kadar imal edilebilmektedir. Bu tip makineler monoray kaldırma grubunda olduğu gibi malzeme taşıma, yükleme, boşaltma, istifleme gibi işlemlerde güvenli olarak kullanılmaktadır. 4 hareketten 12 harekete kadar üretilebilmektedir.

Ağır tonajlı vinçlerimiz ağırlıklı olarak gemi tersaneleri, mermer imalat sektörü, demir-çelik üretim sektörü ve çimento imalat sektörü tarafından tercih edilmektedir. Bu makineler çelik konstrüksiyon çift taraflı kutu profil üzerine döşenen raylar üzerinde hareket eden bir çalışma prensibine sahiptir.

Kumanda gerilimi AC 24 Volta ayarlanmıştır. Motorları gerilim değişikliklerinden korumak için termik manyetik alterler kullanılır.

Pano suya ve ısıya dayanıklıdır. Topraklama bağlantısı ve Acil stop mevcuttur. Kaldırma frenleri DC 24 Volt ile çalışır.

Capacity range of that kind of cranes are between 1000 Kg and 200000 Kg. They are used in almost all production sectors for material loading, unloading, handling operations just as monorail hoisting units. Number of motions are between 4 and 12. Big capacity cranes are usually preferred by Shipyard, Steel Production, Cement and Marble Manufacturing Industry. These machines move upon rails that were welded on two way, assembled on box beams.

Our control voltage is adjusted for AC 24 Volts
Thermic-magnetic switches are used preserve motors
Main Switch Boards are waterproof and salamandrine
Ground Connection and Emergency Stop are exist
Brakes for hoisting are adjusted for DC 24 Volts

- 1 **Redüktör - Kaldırma Motoru - Fren Grubu**
Gearbox - Main Motor - Brake Group
- 2 **Halat Klavuzu**
Rope Guide
- 3 **Elektrik Panosu**
Electrical Pannel
- 4 **Tambur Grubu**
Drum Group
- 5 **Kanca Grubu**
Hook Group
- 6 **Şase Grubu**
Main Body Group

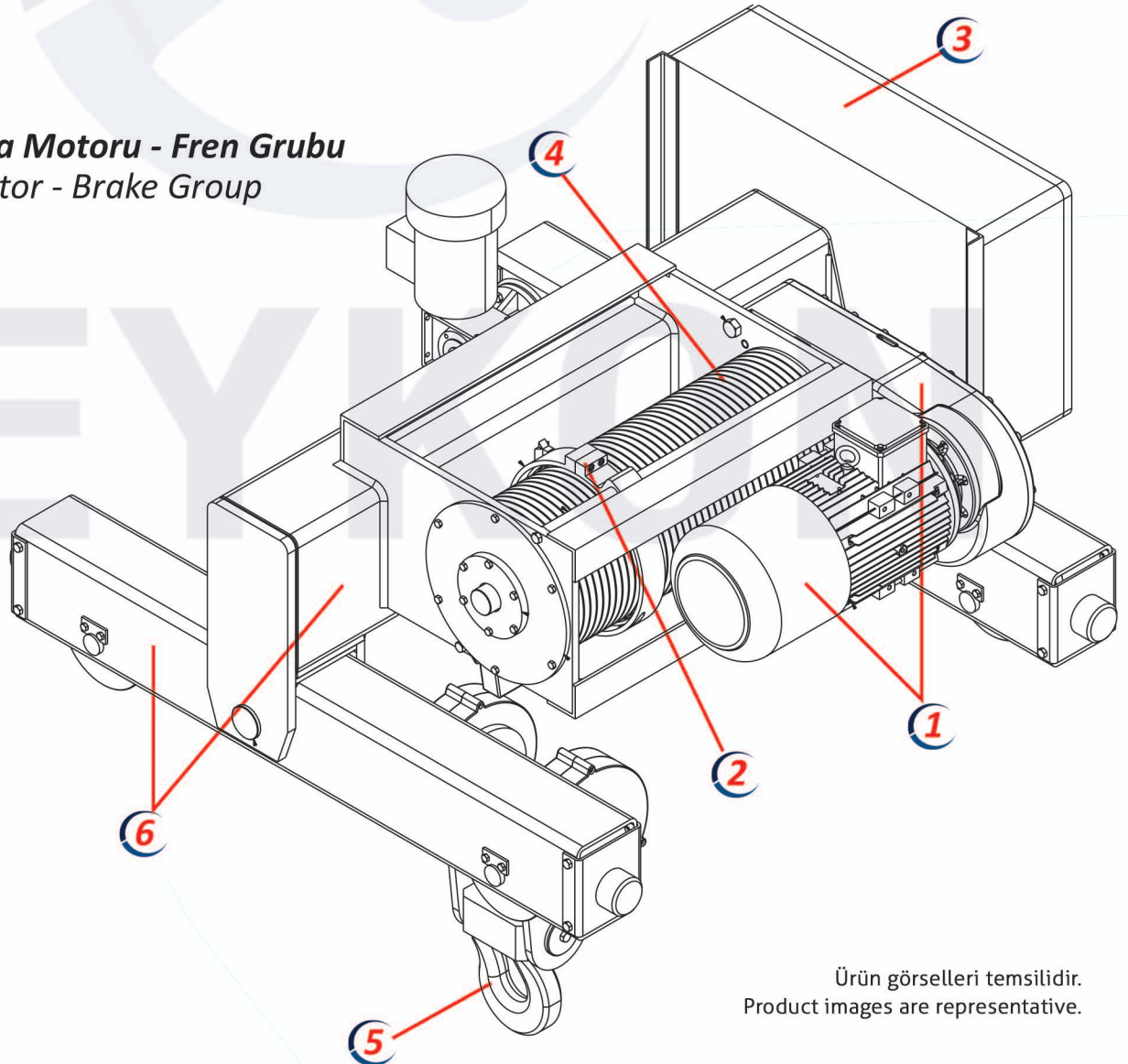

Ürün görselleri temsilidir.
Product images are representative.

- Standart Serisi
- Standard Series

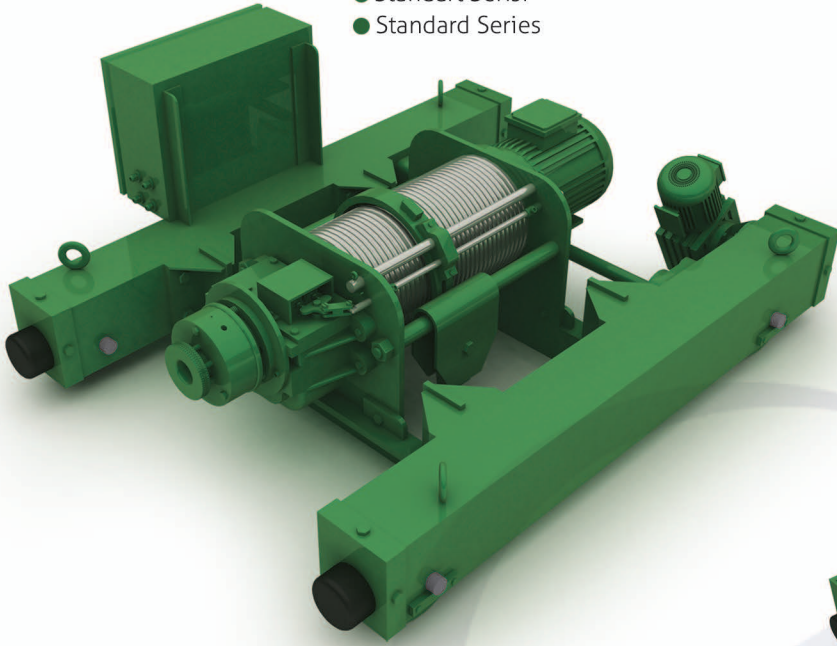

- Yardımcılı Ağır Tip Serisi
- Assisted Heavy Type Series

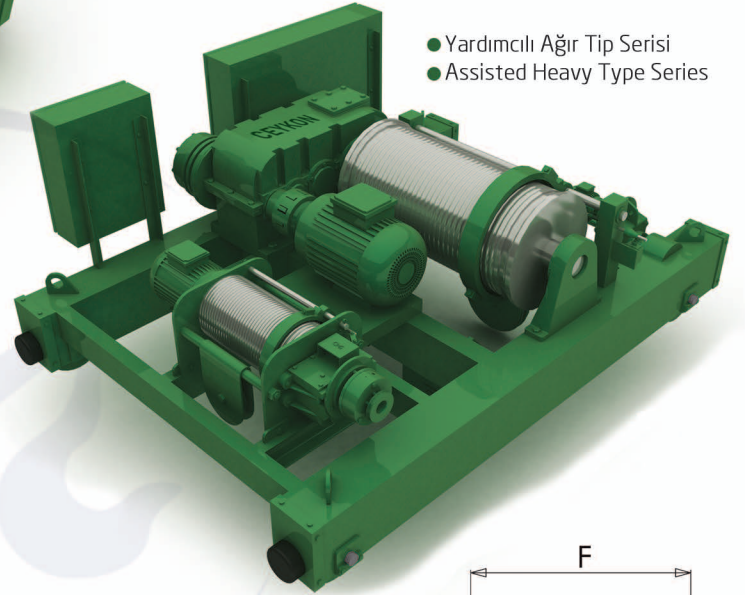

- Sarkık Serisi
- Overhanging Series

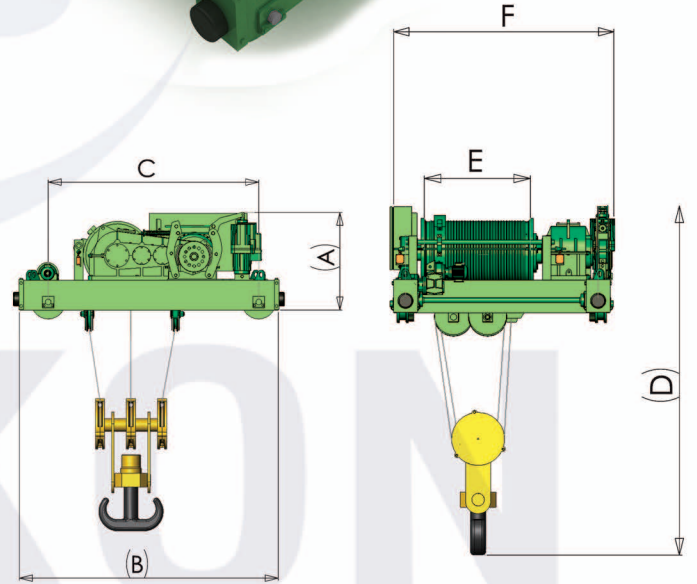
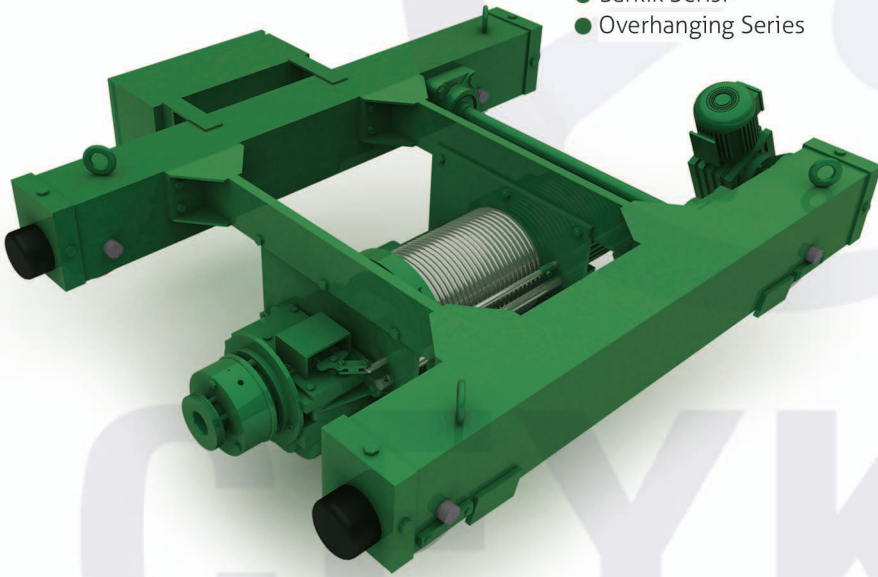

Makine Tipi Machine Type	Kaldırma Kapasitesi Hoisting Capacity	Kaldırma Yüksekliği Hoisting Height	Hareket Sayısı Number Of Motions	Halat Donanımı Rope Falls	Halat Çapı Rope Diameter	TEKNİK VERİ TABLOSU / TECHNICAL DATA CHART					
						Kaldırma Hızı Hoisting Speed		Araba Yürütme Hızı Trolley Travel Speed		Köprü Yürütme Hızı Bridge Travel Speed	
						Standart Standard	Çift Hız Double Speed	Standart Standard	Çift Hız Double Speed	Standart Standard	Çift Hız Double Speed
ARABALI/TROLLEYTYPE	5	57,5 10	6	4	10	3.8	0..4	13	0..20	13	0..20
	7,5	57,5 10	6	4	12	3.6	0..4	13	0..20	13	0..20
	10	57,5 10	6	4	14	3.4	0..4	13	0..20	13	0..20
	20	57,5 10	6	4	18	3	0..3.5	13	0..15	13	0..15
	30	57,5 10	6	6	20	2.8	0..3	13	0..15	13	0..15
	40	57,5 10	6	6	22	2.6	0..3	13	0..10	13	0..10

ÖLÇÜLER / DIMENSIONS

A	90 ~ 120
B	75 ~ 175
C	80 ~ 200
D	30 ~ 80
E	140 ~ 400
F	40 ~ 200

MONORAY KALDIRMA GRUBU

MONORAIL HOISTING GROUP

Bu gruptaki vinçler 500 Kg'dan 20,000 Kg'a kadar olan bir kapasite aralığına sahiptir. Hemen hemen her imalat sektöründe, malzeme yükleme boşaltma ve taşıma işlemlerinde kullanılabilirlerdir.

İki hareketten toplam 12 harekete kadar üretilebilmektedir. İki hareketli makineler sadece indirme-kaldırma işlevi görmekte olup genellikle sabit vinçler olarak adlandırılırlar. Diğer 4 ve üzeri harekete sahip olan makinelerimiz ise I profilden imal edilmiş bir köprü üzerinde hareket sayısına bağlı olarak aşağı - yukarı, sağ-sol, ileri - geri hareket etmektedir. Makinelerimiz olası sorunlara ve zorlamalara karşı limit siviçleri ile donatılmıştır. Kaldırmada kullanılan redüktör dişlileri 7131 malzemeden gövde ise dökme demirden şirketimiz tarafından üretilmektedir. Dişli-lerdeki mukavemetin artırılması için sementasyon işlemi yapılmaktadır.

Kumanda gerilimi AC 24 Volta ayarlanmıştır. Motorları gerilim değişikliklerinden korumak için termik manyetik şalterler kullanılır.

Pano suya ve ısıya dayanıklıdır. Topraklama bağlantısı ve Acil stop mevcuttur. Kaldırma frenleri DC 24 Volt ile çalışır.

Capacity range of that kind of cranes are between 500 Kg and 20 000 Kg. They are used in almost all production sectors for material loading, unloading, handling operations. Number of motions are between 2 and 12. Units for 2 motions are called as Stable Cranes and is used just for lift & break. Others travel on a bridge that is made from I Beam and moves right&left, up&down, Front&Rear depending on number of motions. Limit Switches are fixed against possible damages. 7131 steel material is used for gears inside main hoisting gearbox. Besides, these gears and boxes are made in our factory. In order to increase strength of gears cementation process is carried out to our gears.

Our control voltage is adjusted for AC 24 Volts
Thermic-magnetic switches are used to preserve motors.
Main Switch Boards are waterproof and salmandrine.

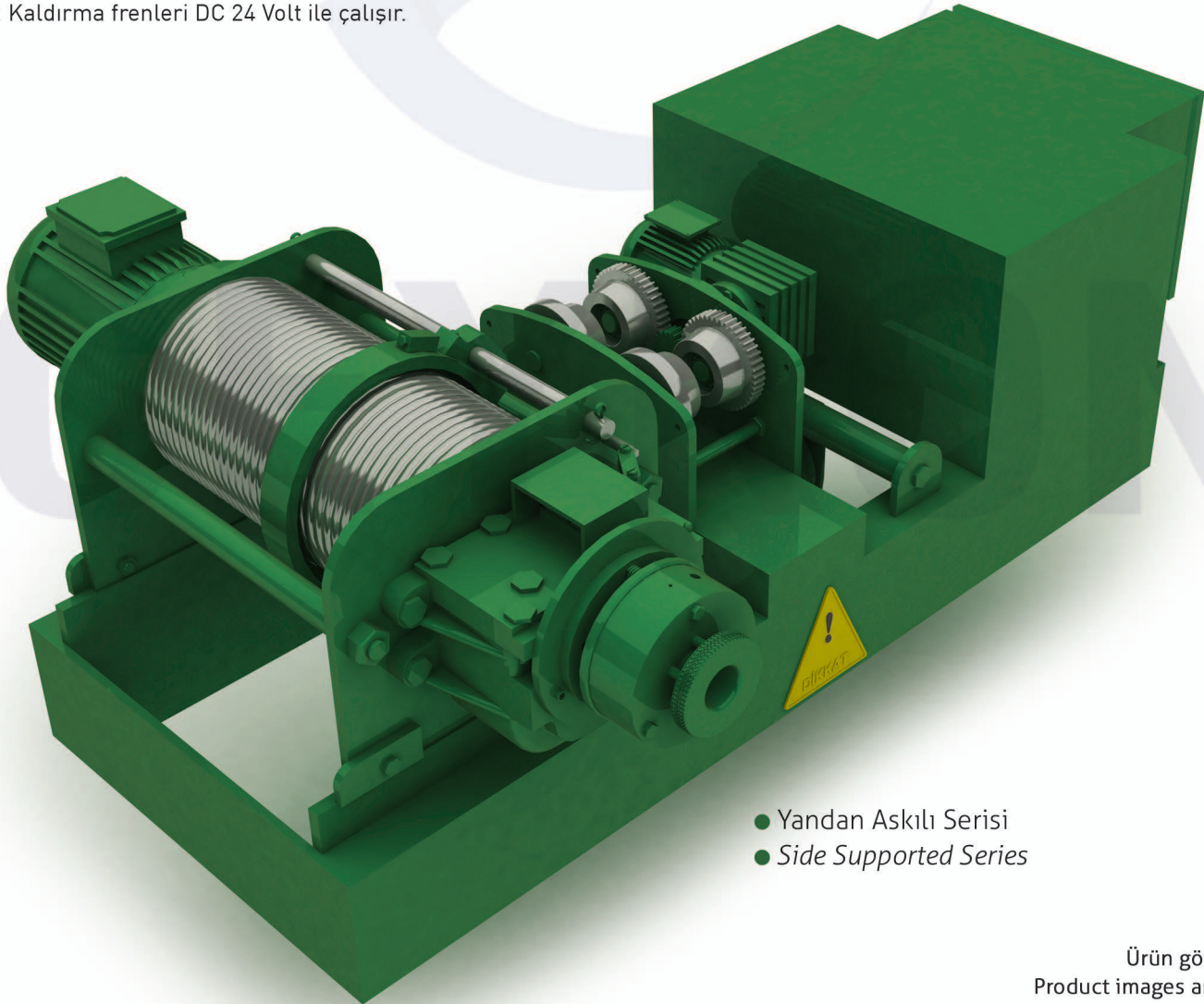

- Yandan Askılı Serisi
- Side Supported Series

Ürün görselleri temsilidir.
Product images are representative.

- Döner Başlıklı Seri
- Revolving Head Series

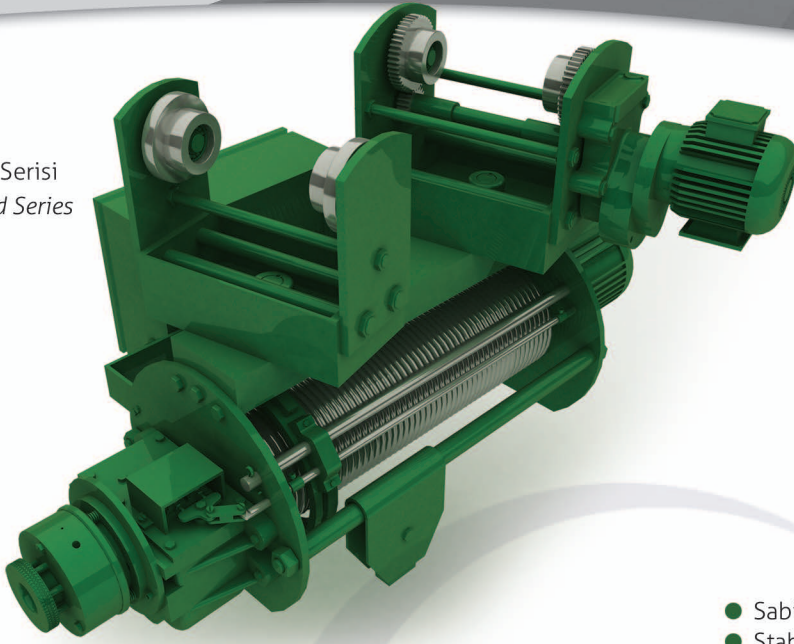

- Sabit Seri
- Stable Series

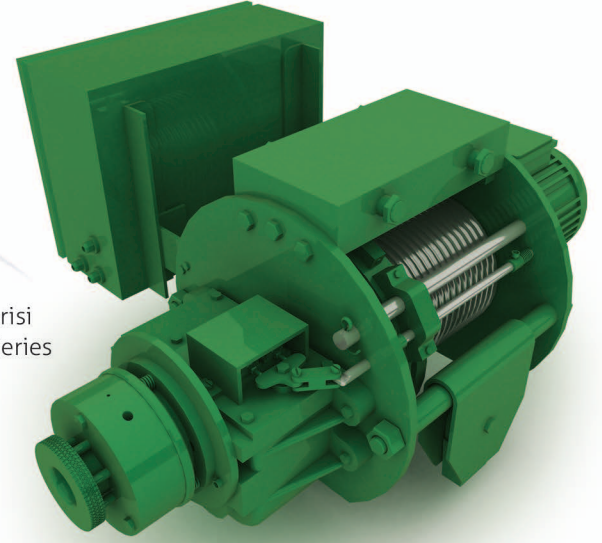

- Standart Seri
- Standard Series

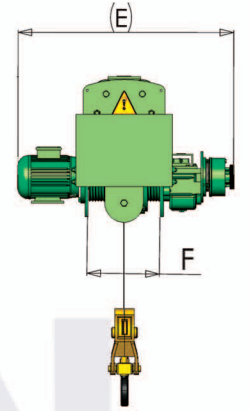
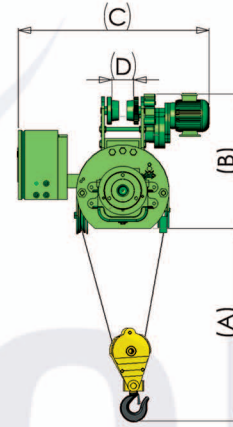
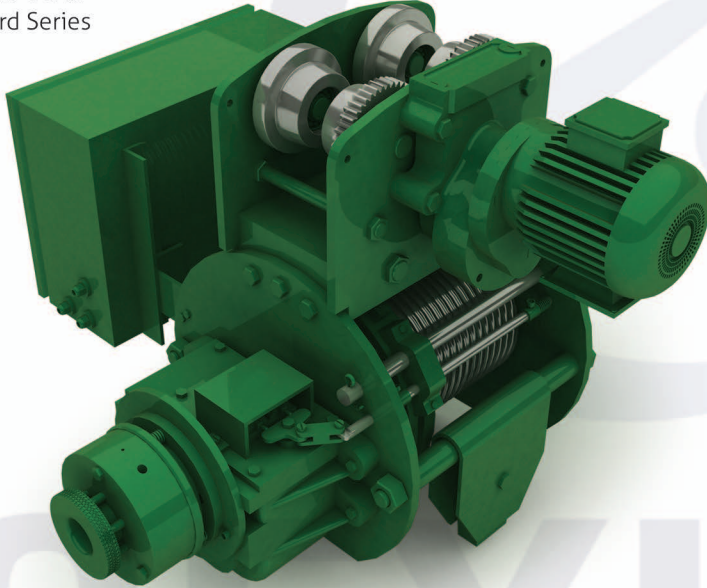

TEKNİK VERİ TABLOSU / TECHNICAL DATA CHART

Makine Tipi Machine Type	Kaldırma Kapasitesi Hoisting Capacity	Kaldırma Yüksekliği Hoisting Height	Hareket Sayısı Number Of Motions	Halat Donanımı Rope Falls	Halat Çapı Rope Diameter	TEKNİK VERİ TABLOSU / TECHNICAL DATA CHART					
						Kaldırma Hızı Hoisting Speed		Araba Yürütme Hızı Trolley Travel Speed		Köprü Yürütme Hızı Bridge Travel Speed	
						Standart Standard	Çift Hız Double Speed	Standart Standard	Çift Hız Double Speed	Standart Standard	Çift Hız Double Speed
SABİT/ STABLE	0,5	57,5 10	2	2	6	5,2	4...8	13	10...20	13	10...20
	1	57,5 10	2	2	8	5,2	4...8	13	10...20	13	10...20
	2	57,5 10	2	2	10	5,2	4...8	13	10...20	13	10...20
	3	57,5 10	2	4	8	2,6	2...8	13	10...20	13	10...20
	5	57,5 10	2	4	10	2,6	2...8	13	10...20	13	10...20
MONORAY/ MONORAIL	0,5	57,5 15	4-6	2	6	5,2	4...8	13	10...20	13	10...20
	1	57,5 15	4-6	2	8	5,2	4...8	13	10...20	13	10...20
	2	57,5 15	4-6	2	10	5,2	4...8	13	10...20	13	10...20
	3	57,5 15	4-6	4	8	2,6	2...4	13	10...20	13	10...20
	5	57,5 15	4-6	4	10	2,6	2...4	13	10...20	13	10...20
	7,5	57,5 15	4-6	6	10	1,3	1...2	13	10...20	13	10...20
10	57,5 15	4-6	6	10	2,7	2...4	13	10...20	13	10...20	

ÖLÇÜLER / DIMENSIONS

A	50 ~ 80
B	5.8 ~ 21,5
C	40 ~ 60
D	30 ~ 60
E	70 ~ 250
F	30 ~ 190

PORTAL KÖPRÜLER GANTRY BRIDGES

Bu grup köprüler tonaj ve açıklığa bağlı olarak ST 37 veya ST 44 çelik konstrüksiyondan üretilmiş karşılıklı iki kutu profilin bir ara bağlantı parçası ile bağlanmasından oluşurlar. Çift kirişli vinçlerden farklı olarak dış ortamda dört adet ayak üzerinde hareket ederler ve çok yüksek kaldırma kapasitelerine sahiptirler.

Yoğun olarak Demir-Çelik endüstrisi, Gemi inşa sektörü, Mermer imalat sektörü ve Limanlarda kullanılmaktadır. 2 tondan 200 tona kadar çeşitli açıklıklarda üretilebilmektedir.

These type of bridges are manufactured by connecting two box beams with a middle connection piece using ST 37, 44 and 52 materials. These bridge group is for outdoor use, travels upon 4 legs and has very big hoisting and handling capacities.

They mostly preferred by Steel Production, Shipyard, Marble Manufacturing Industry and by Harbours. Capacity range is between 2 000 Kgs and 200 000 Kgs.



- **Küt Portal Köprüler**
- **Blind Overhead Gantry Bridges**



- **Küt Monoray Portal Köprüler**
- **Blind Monorail Gantry Bridges**



- **Yarım Portal Köprüler**
- **Semi Gantry Bridges**



- **Tek Çıkıntılı Portal Köprüler**
- **Extended Gantry Bridges**

Ürün görselleri temsilidir.
Product images are representative.

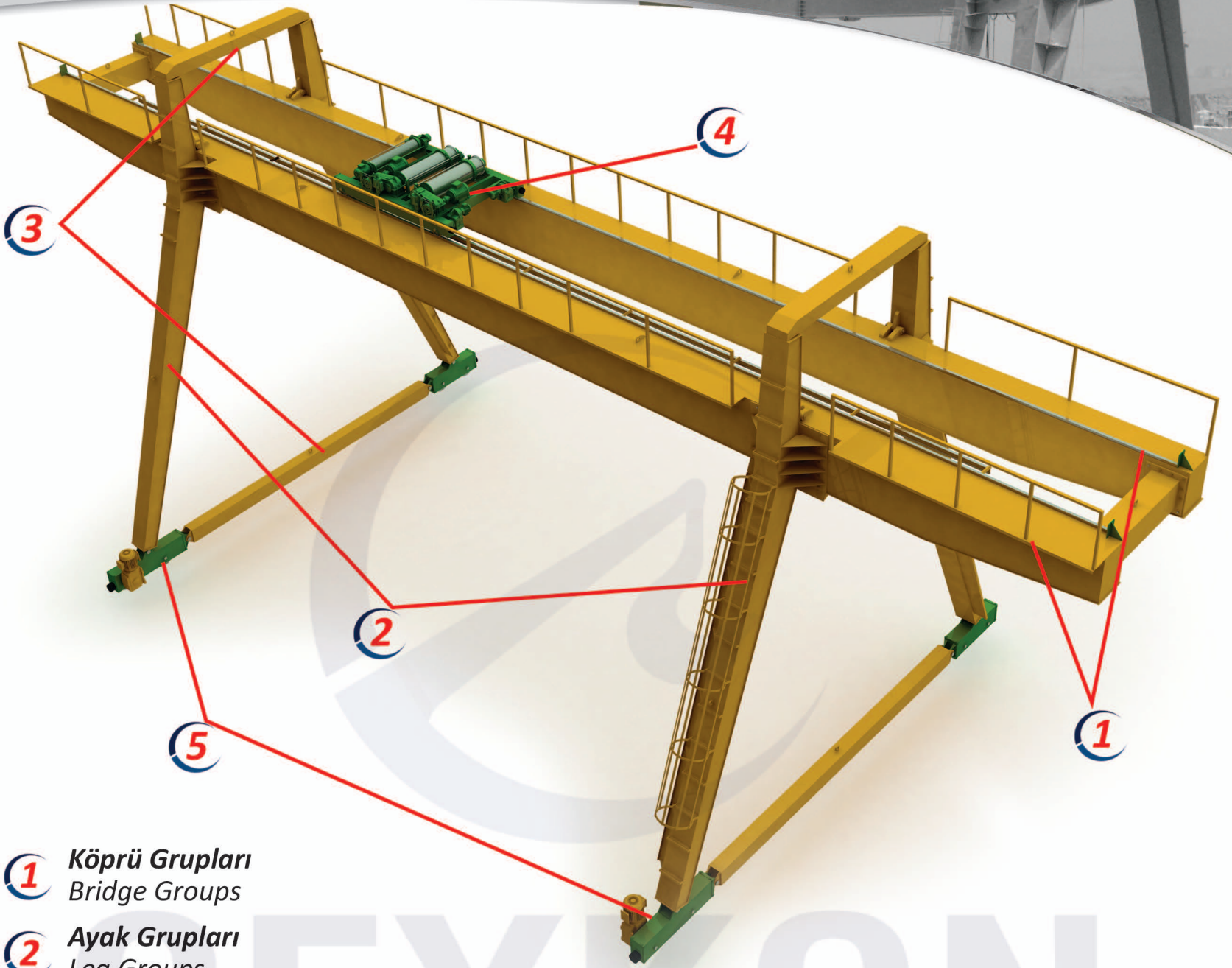

- 1** Köprü Grupları
Bridge Groups
- 2** Ayak Grupları
Leg Groups
- 3** Bağlantı Grupları
Connection Groups
- 4** Vinç Grupları
Trolley Groups
- 5** Yürüyüş Grupları
Endcarriages Groups

A	Köprü Aks Açıklığı / Bridge Axle Span
B	Toplam Köprü Açıklığı / Total Bridge Span
C	Araba Aks Açıklığı / Trolley Axle Distance
D	Kaldırma Yüksekliği / Hoisting Height

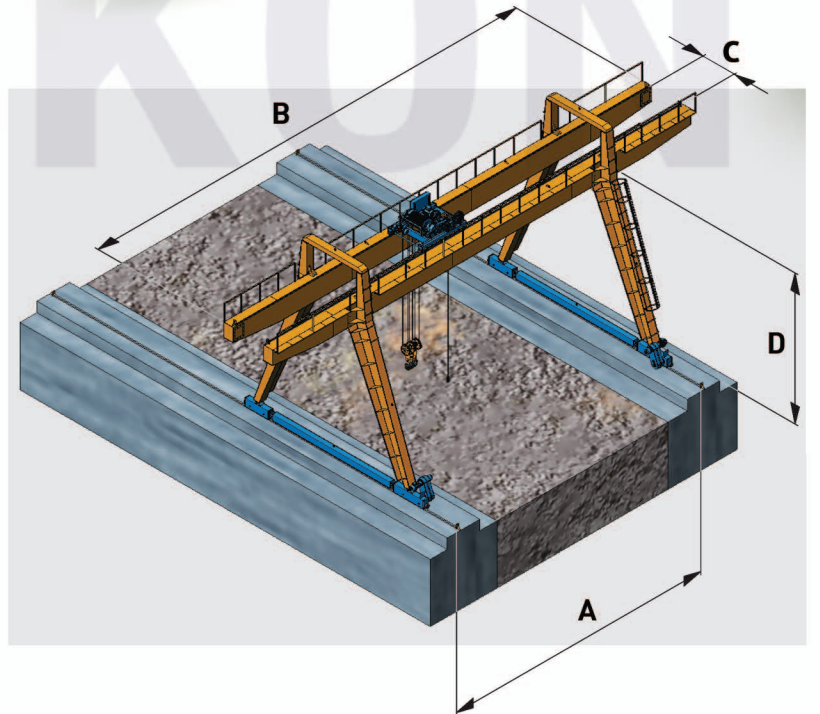

TEK ve ÇİFT KİRİŞLİ KÖPRÜLER SINGLE and DOUBLE GIRDER BRIDGES

Bu köprü grubu, ST 37, St 44 veya St 52 malzemeden sacların kaynatililarak kutu profil haline dönüştürülmesi suretiyle yapılmaktadır. Vinç arabası bu köprü üzerine kaynatılmış raylar üzerinde hareket eder. Bu grup köprüler yüksek tonajın ve hareket hassasiyetinin istendiği atölye ve depolarda kullanılmaktadır. Alt sınır olmamakla beraber 40 metreye kadar yüksek tonajları için üretilebilmektedir.

This bridge group is use for indoor and manufactured by welding sheets and formed it to Box Beam using ST 37,44 or 52 material.Crane trolley is moved upon rails which were welded to the crane box beams.Bridge span can be adjusted up to 40 meters and for heavy loads .They are usually prefed by customers who needs high capacities and movement sensivity.





- | | |
|---|---|
| A | Çatı Makası ile Guse Arası Mesafe
Distance Between Roof Truss and Pillar Hangers |
| B | Köprü Açıklığı / Bridge Span |
| C | Kaldırma Yüksekliği / Hoisting Height |
| D | Hol Boyu / Long Travel Length |
| E | İki Sütun Arası Mesafe / Distance Between Two Pillars |

BLOK ÇEVİRME MAKİNELERİ

MARBLE BLOCK ROTATING MACHINES

Mermer ve granit bloklarının 90 derecelik ekseninde döndürülmesini kolaylaştırmak amacıyla tasarlanmıştır. Bu makine ile 30-40-50 tona kadar olan mermer blokları kumanda vasıtasıyla çevrilebilmektedir. Makine gövdesi ST 37 Kalitesinde çelik konstrüksiyondan imal edilmiştir. Çevirme işlemi hidrolik olarak yapılmakta olup, 5 kademeli bir pistonla sağlanmaktadır. Çevirme esnasında, pistonlardan biri yükü kaldırırken karşı tarafında bulunan piston yükü tutmaktadır. Böylelikle, emniyetli bir çevirme gerçekleştirilmiş olur.

Block Rotating Machine was designed to simplify turning marble or granite blocks in the horizon of 90 degrees. Loads up to 30-40-50 tons can be turned over by a control easily. Machine body is manufactured using ST 37 steel construction.

Rotating process is made by hydraulic system and 5 stage piston. One of the pistons elevates and other hold the load at the time of rotation. Hence, a reliable turning actualizes.

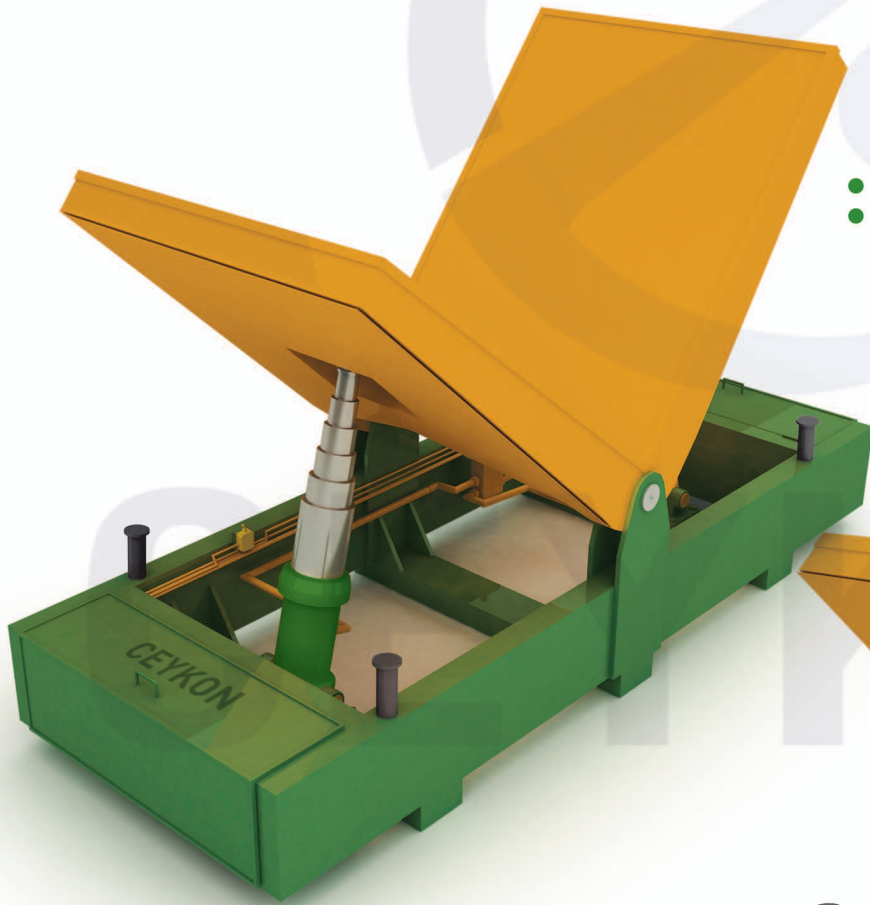

- Tek Pistonlu Serisi
- Single Piston Series

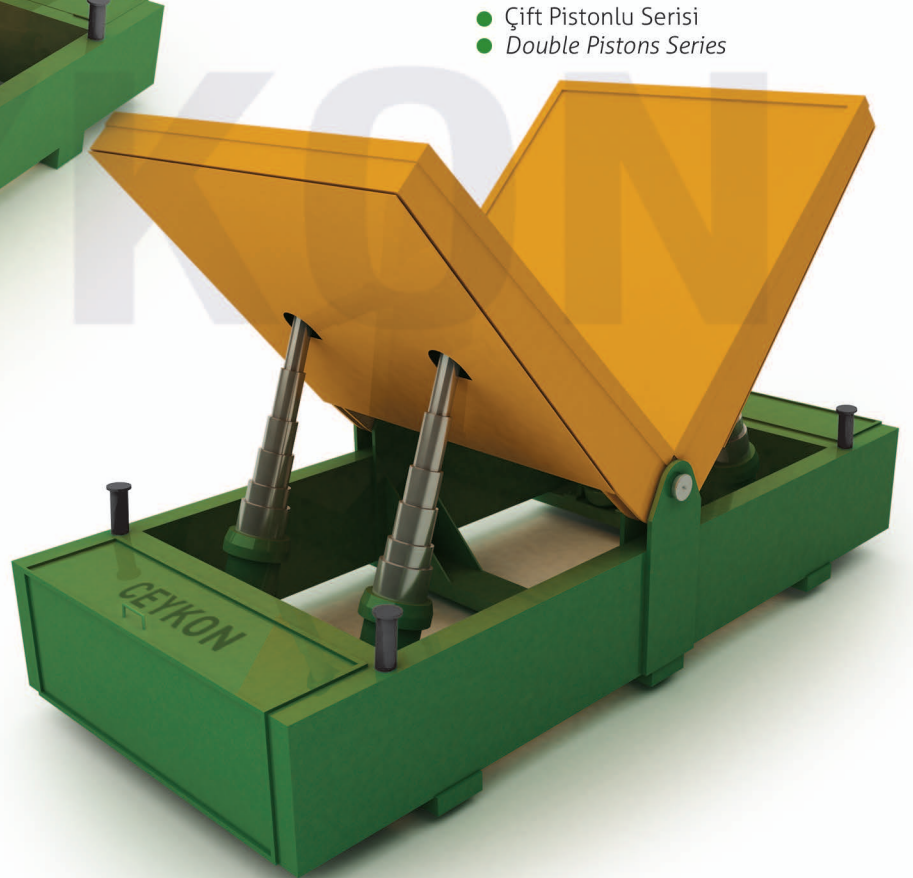

- Çift Pistonlu Serisi
- Double Pistons Series

PERGEL VİNÇLER

JIB CRANES

Zemine sabitlenmiş bir taşıyıcı gövde ve bu gövdeye monte edilmiş bir koldan oluşmaktadır. Vinç, bu kol üzerinde hareket etmektedir, kol uzunluğu maksimum 5 mt ve kolun hareketi 180 derecedir. İmalat sektöründe, genellikle tezgâh yanlarında ağır parçaların kaldırılması amacıyla kullanılmaktadır.

That cranes are composed of a carrier trunk settled down to floor and a rod fixed on trunk and crane travels on that rod. Rod length is maximum 5 meters and travels 180 degrees. Jib cranes are generally used in production sector to lift up loads that can not be able to lift by human force near workbenches.



Ürün görselleri temsilidir.
Product images are representative.

REFERANSLARIMIZ





















EXTRA EKİPMANLAR

EXTRA EQUIPMENTS

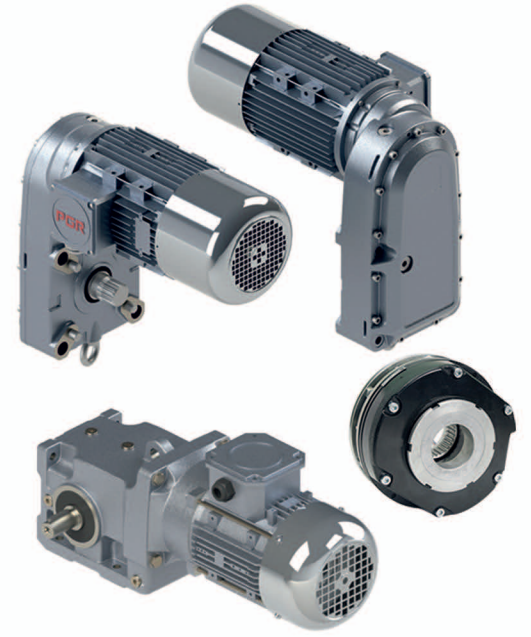

Redüktör ve Fren Grupları
Gearbox and Brake Groups



Dijital Yük Ölçer
Digital Scale



Frekans İvertörü
Frequency Inverter



Uzaktan Kumanda
Wireless Remote Control



Kablo Tamburu
Cable Reel

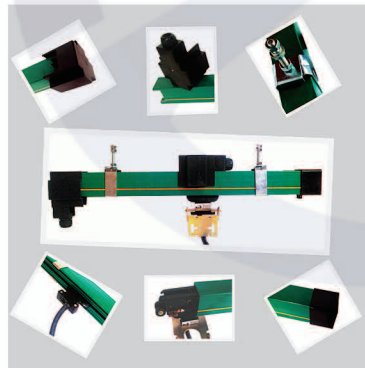

Kapalı Bara Sistemi
Trolley Busbar



Plaka Yükleme Aparatı
Marble Carrying Materials

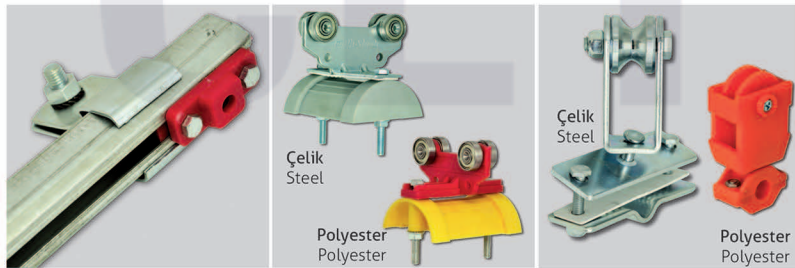

Çelik
Steel

Polyester
Polyester

Çelik
Steel

Polyester
Polyester

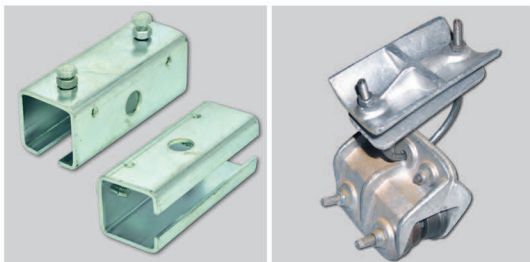

C Profil Malzemeleri
C Profile Materials



Sevkiyat
Transport

İÇ VİNÇ BİLGİ FORMU / OVERHEAD TRAVELLING CRANE FORM

Yetkili Kişi / Responsible Person		Firma İsmi / Company Name	
Ünvan / Job Title		Adres / Address	
E-mail bilgileri / e-mail address			
Cep Numarası / Gsm Number		Telefon Numarası / Phone Number	
Tarih / Date		Fax Numarası / Fax Number	

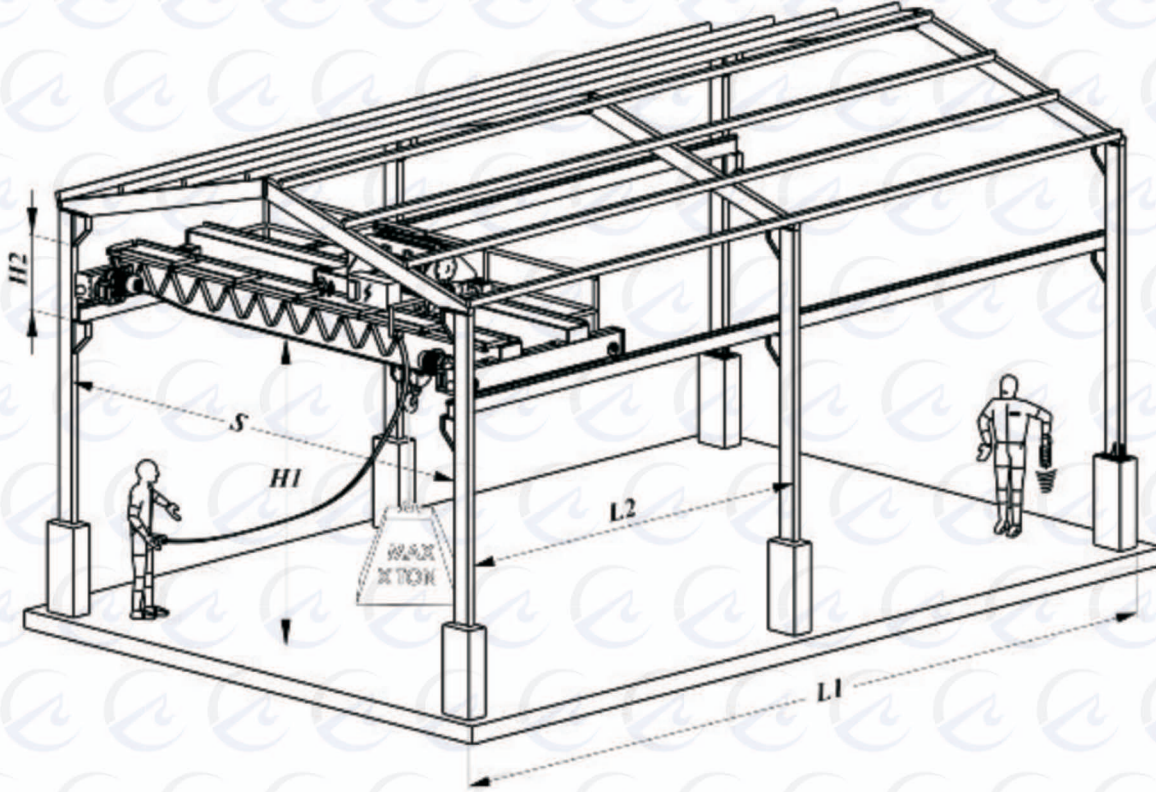

Lütfen Boş Alanları Doldurunuz / Please Fill The Fields Below

Çift Kirişli Vinç / Double Girder	Tek Kirişli Vinç / Single Girder
Kaldırma Kapasitesi / Lifting Capacity (X)	
Köprü Geniřliđi / Span (S)	
Yürüme Yolu Uzunluđu / Travelling Length (L1)	
Direk Merkez / Column Center (L2)	
Kaldırma Yüksekliđi / Lifting Height (H1)	
Uzaktan Kumanda / Wireless Remote Control	
Vinç Direkleri / Crane Beams (B)	
Yanyol Rayları / Rails (R)	

NOTLAR / NOTES

1	
2	
3	

PORTAL VİNÇ BİLGİ FORMU / GANTRY CRANE FORM

Yetkili Kişi / Responsible Person		Firma İsmi / Company Name	
Ünvan / Job Title		Adres / Address	
E-mail bilgileri / e-mail address			
Cep Numarası / Gsm Number		Telefon Numarası / Phone Number	
Tarih / Date		Fax Numarası / Fax Number	

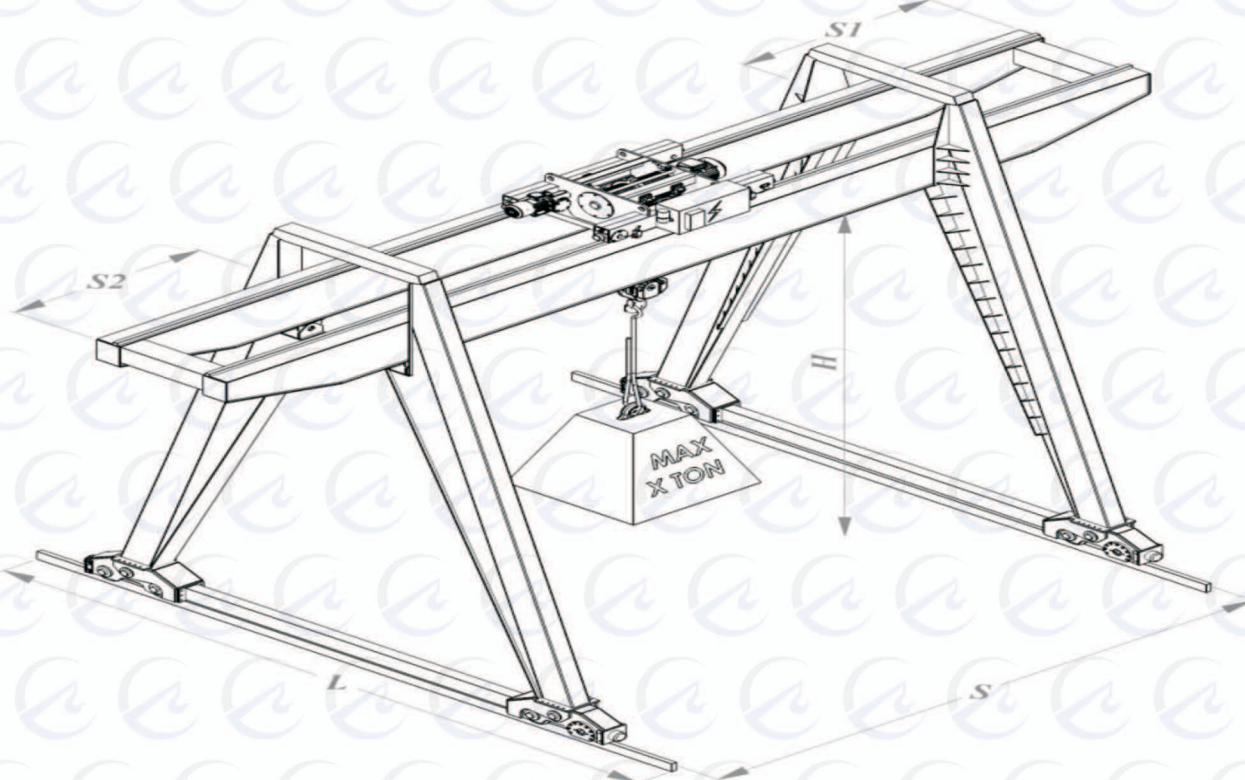

Lütfen Boş Alanları Doldurunuz / Please Fill The Fields Below

Çift Kirişli Vinç / Double Girder		Tek Kirişli Vinç / Single Girder	
Kaldırma Kapasitesi / Lifting Capacity (X)			
Köprü Geniřliđi / Span (S)			
Sađ Taraf Çıkıntısı / Right Side Extention (S1)			
Sol Taraf Çıkıntısı / Left Side Extention (S2)			
Kaldırma Yüksekliđi / Lifting Height (H1)			
Yürüme Yolu Uzunluđu / Travelling Length (L1)			
Uzaktan Kumanda / Wireless Remote Control			
Yanyol Rayları / Rails (R)			

NOTLAR / NOTES

- 1
- 2
- 3



SİPARİŞ 01

CEYKON Makine olarak siz değerli müşterilerimize çözüm odaklı hizmet vermek için, uzun yıllardır sektörde çalışmış tecrübeli iş arkadaşlarımız siparişlerinize istediğiniz özelliklerde ve en uygun fiyat teklifinin hazırlanıp onayınıza sunulma aşaması.



UZMAN KADRO 02

CEYKON Makine olarak siz değerli müşterilerimize siparişlerinize en uygun fiyat teklifizi verip onay aldıktan sonra; Uzman mühendis kadromuz ile siparişinizi değerlendirip fizibilite çalışmasına başladığımız aşama.



ÜRETİM 03

CEYKON Makine olarak siz değerli müşterilerimizin siparişi doğrultusunda fizibilite çalışması yapıldıktan sonra üretime başladığımız aşama.



KALİTE KONTROL 04

CEYKON Makine olarak siz değerli müşterilerimizin siparişi doğrultusunda vinç üretimini tamamlayıp, teslim etmeden önce vinç'in kalite kontrol işlemine başladığımız aşama.



TESLİMAT 05

CEYKON Makine olarak siz değerli müşterilerimizin siparişi doğrultusunda üretilen vinç'in Kalite Kontrol işlemi yapıldıktan sonra Güvenli ve Hızlı Teslimat için Vinçi paketlenme ve yüklemeye başladığımız aşama.

www.ceykon.com.tr



/ceykonmakine



/ceykonmakine



/ceykonvinc

Teknik bilgiler yol gösterici olup, bağlayıcı değildir. Ölçüleri, özellikleri değiştirme ve geliştirme hakkımız saklıdır.
Technical specialty is guider but not connective. Our changing right about size and feature is secret.

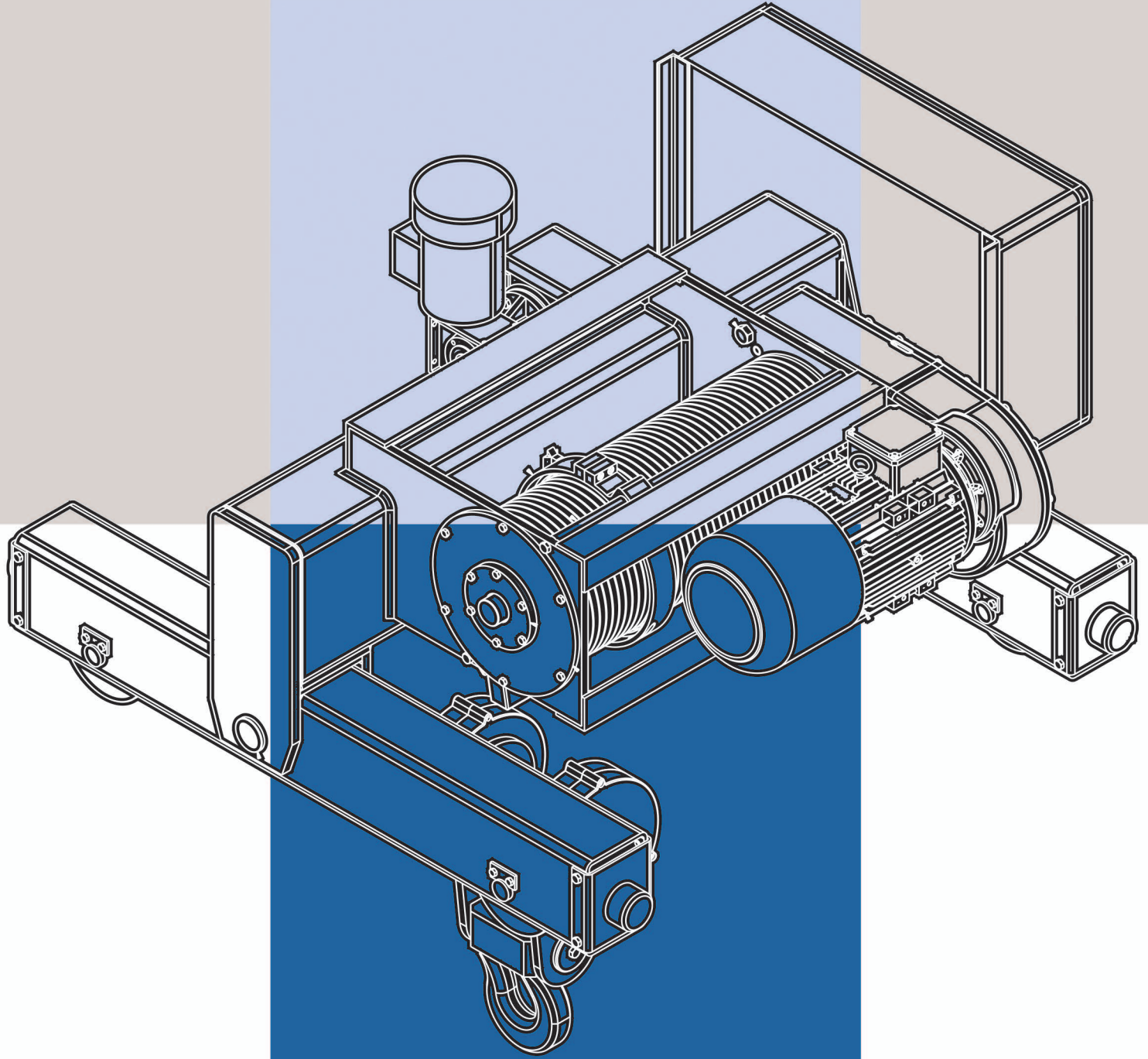

 **CEYKON**
MAKİNE METAL SAN. ve TİC. LTD. ŞTİ.



1. Organize Sanayi Bölgesi Çarman Sk. No: 9
SELÇUKLU / KONYA / TÜRKİYE
Tel: +90 332 248 39 00 (pbx) Fax: +90 332 248 39 02
www.ceykon.com.tr E-mail: info@ceykon.com.tr

